

Introduction to Computer Networks



IEEE 802.1D Spanning Tree Algorithm

© All rights reserved. No part of this publication and file may be reproduced, stored in a retrieval system, or transmitted in any form or by any means, electronic, mechanical, photocopying, recording or otherwise, without prior written permission of Professor Nen-Fu Huang (E-mail: nfhuang@cs.nthu.edu.tw).

Outline

- **Introduction**
- **Frames Forwarding and Addresses Learning**
- **Loop Problem and Resolution**
- **Spanning Tree Algorithm**
- **Spanning Tree Maintenance**

A Simple Bridge Example

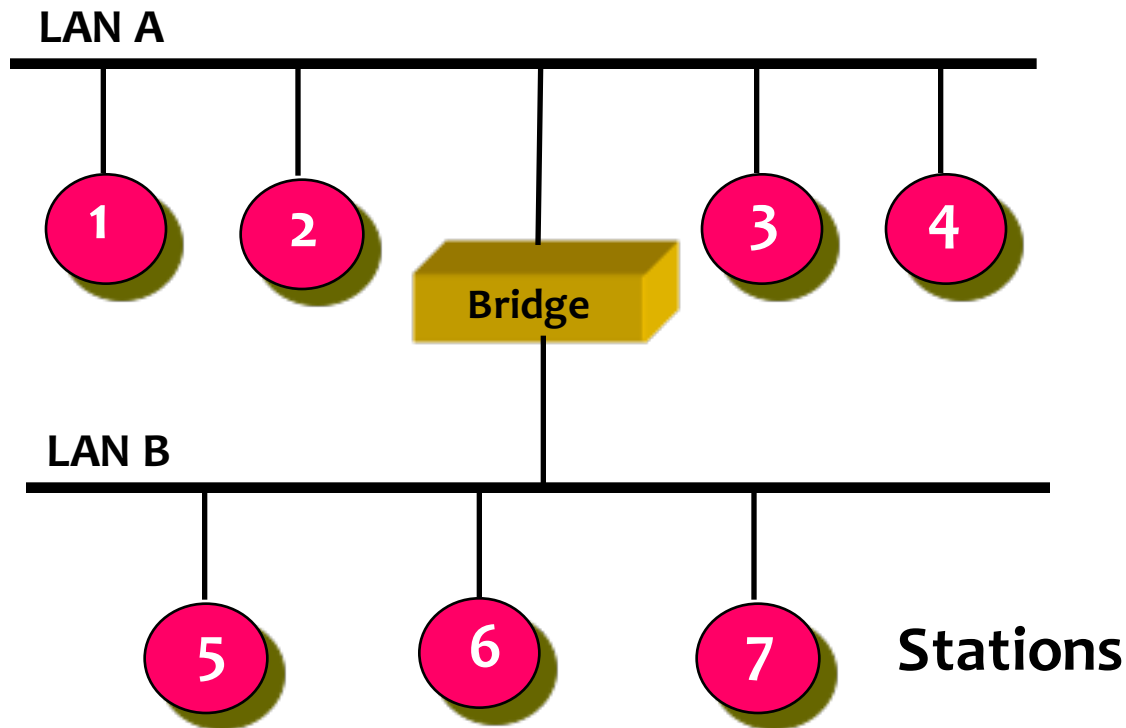

What is a Bridge ?

- A bridge is a **MAC layer (layer 2) device** which relays frames among physically separated LANs and makes the physical LANs appear as **one logical LAN** to the end stations

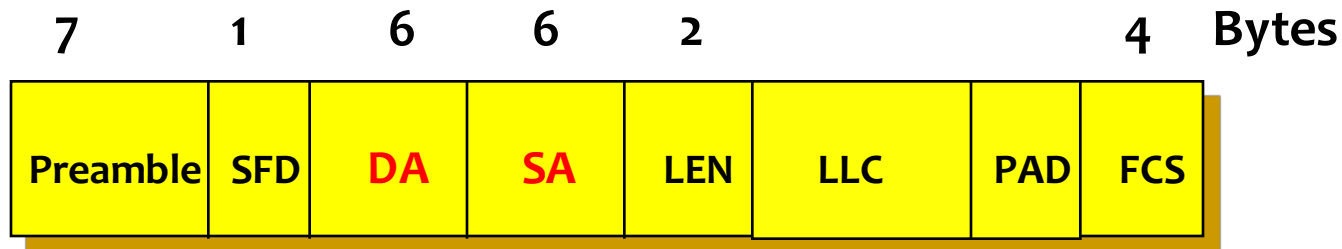

The Concept of One Logical LAN

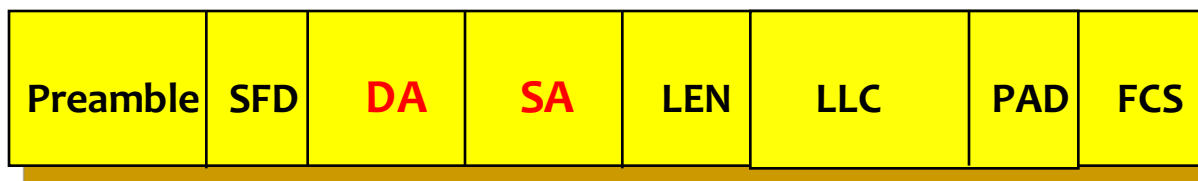
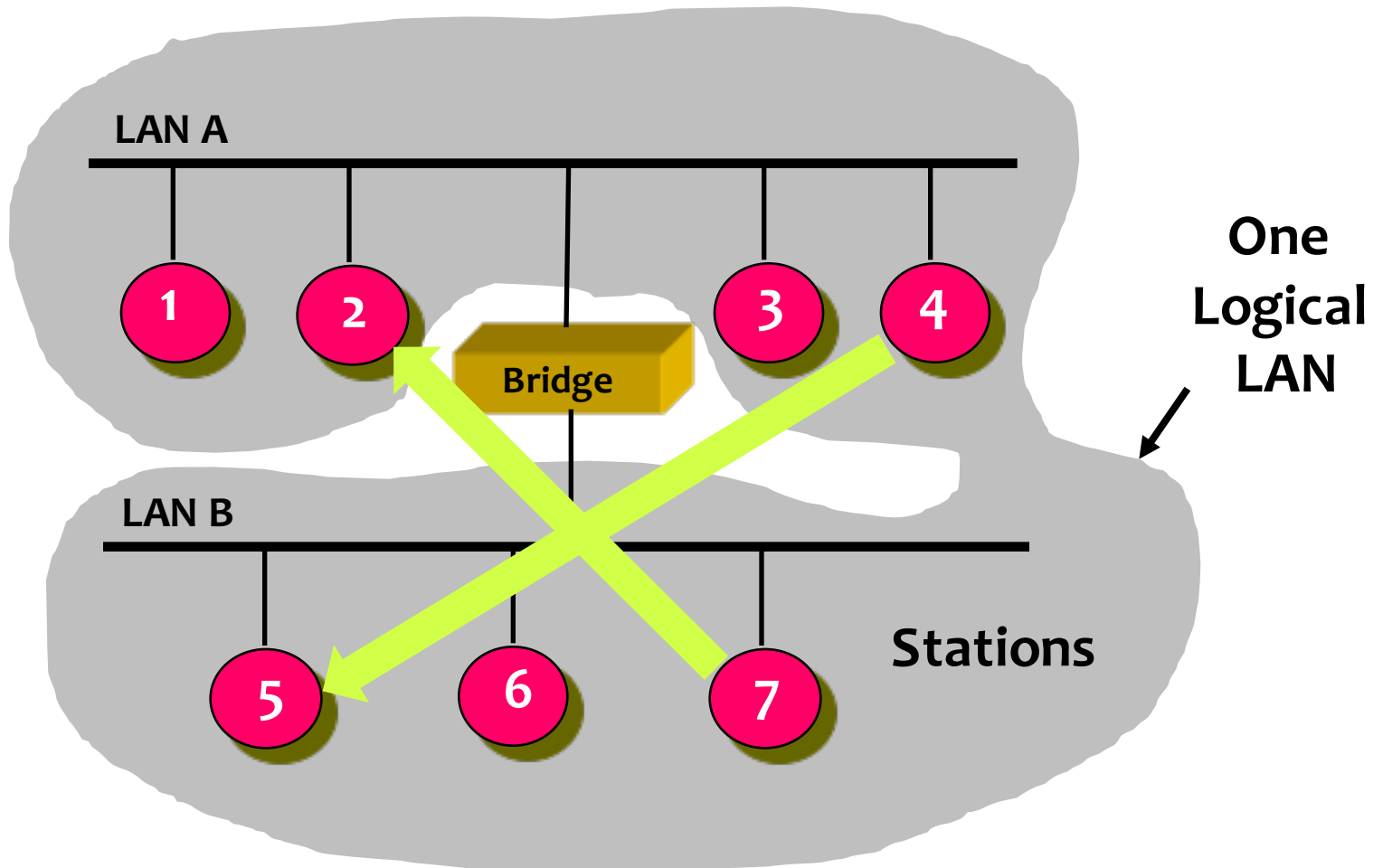

MAC_3 MAC_4

Functions of a Bridge

■ Basic Functions:

- Frame **Forwarding** and **Filtering**
- Address **Learning**
- Resolving Possible **Loops** in the Topology

■ Additional Functions:

- Congestion Control (Enough Buffer)
- Static Filtering (Security)
- Translation (Multi-Bridge)
- Routing (Multi-Bridge)
- Segmentation

Design Considerations

- No modifications to the content or format of the frames
- Contain enough buffer space to meet peak demands
- Contain addressing and routing intelligence
- A bridge may connect more than two networks
- Why **Bridged LANs (BLAN)**?
 - Reliability
 - Performance
 - Security
 - Geography

Bridge Routing

- The Bridges must be equipped with a **routing capability**
- The routing decision may not always be a simple one (loop)
- **Topology changes** have to be considered
- A bridge knows all the station addresses (**Filtering Database**)

A BLAN Example Without loop

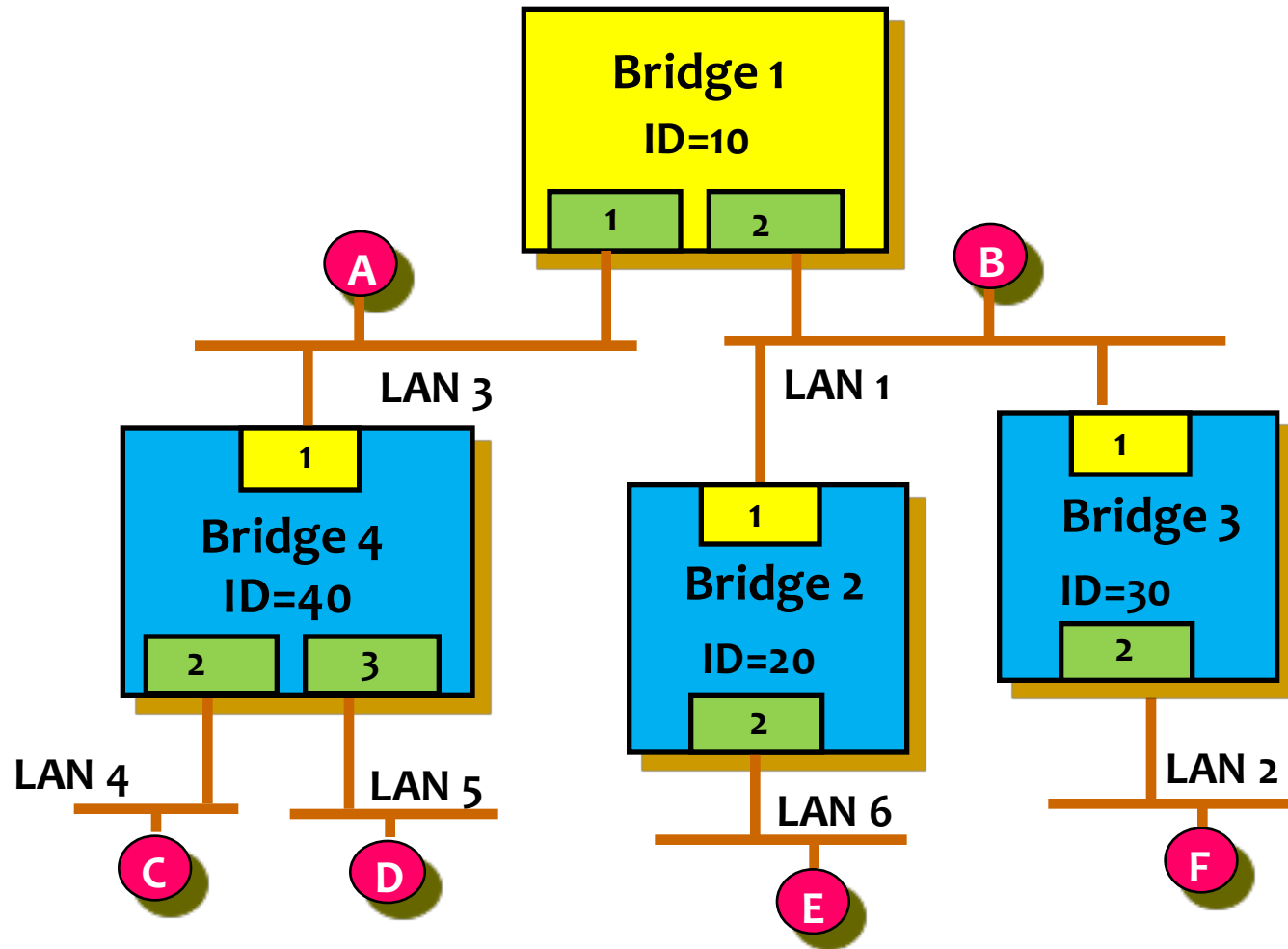

A BLAN Example with Loops

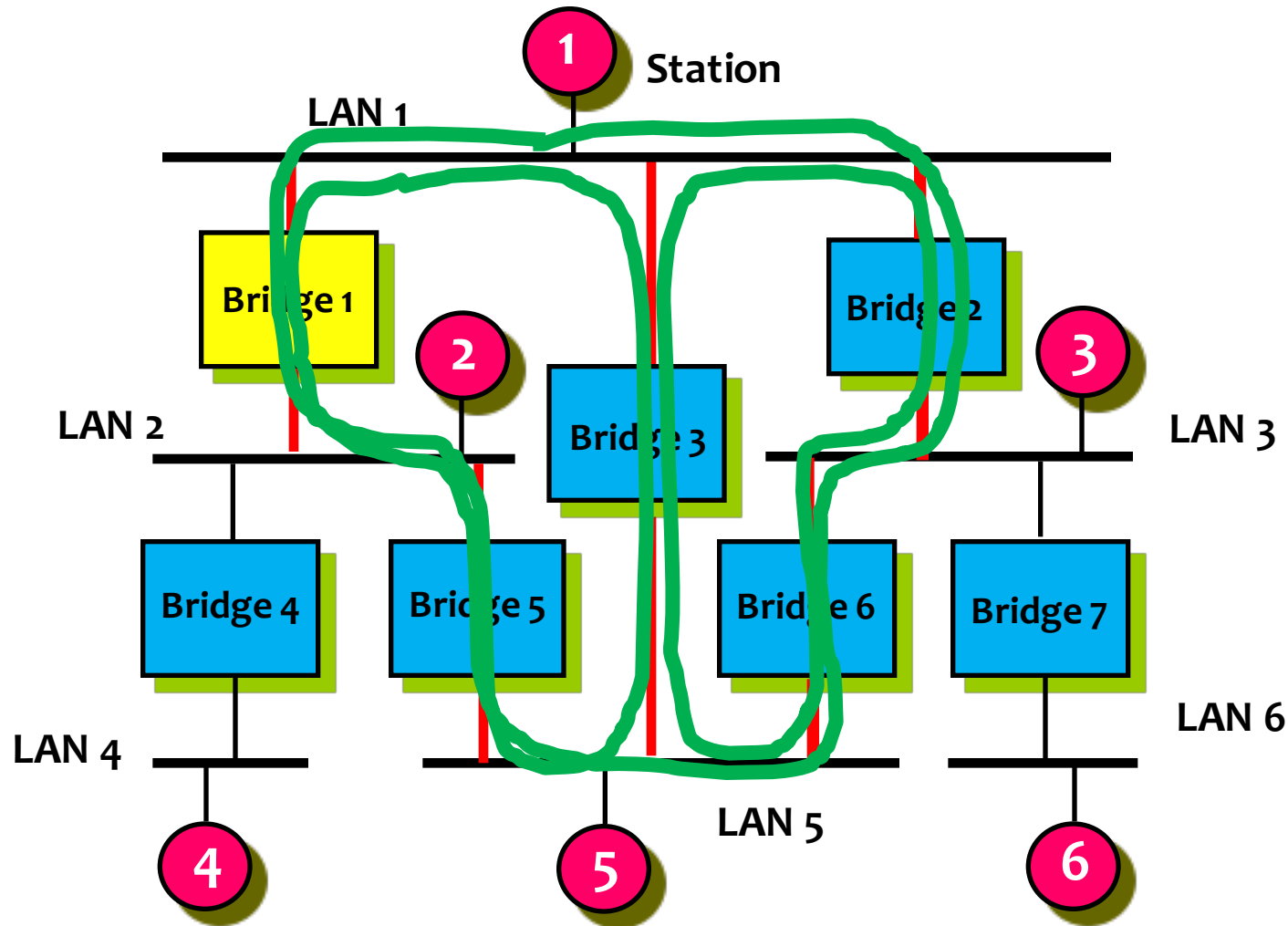

Bridge Protocol Architecture

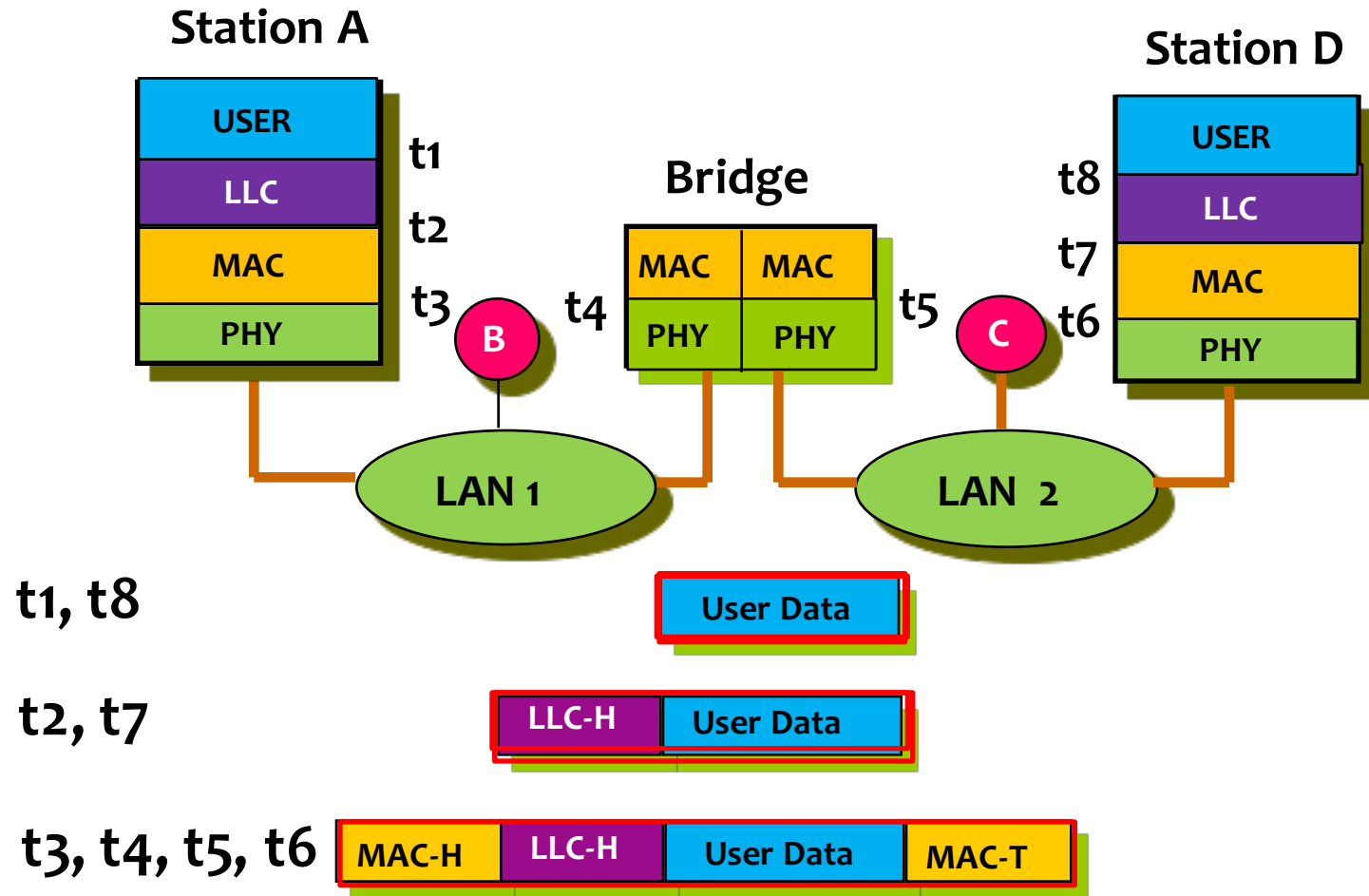

Spanning Tree Routing

■ Frame Forwarding and Filtering

- Use the **destination MAC address (DMAC)** field in each MAC frame
- A bridge maintains a filtering database with entries:
[Address, Port, Time]

■ Address Learning

- Use the **source MAC address (SMAC)** field in each MAC frame
- If the element is already in the database, the entry is updated and the timer is reset
- If the element is not in the database, a new entry is created with its own timer

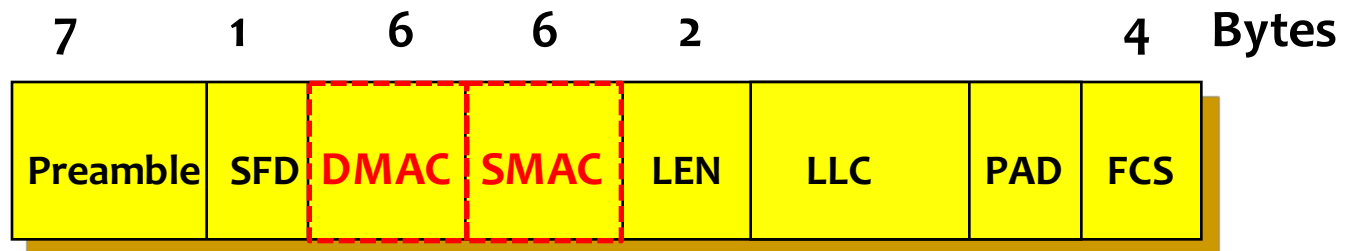

Filtering Database Examples

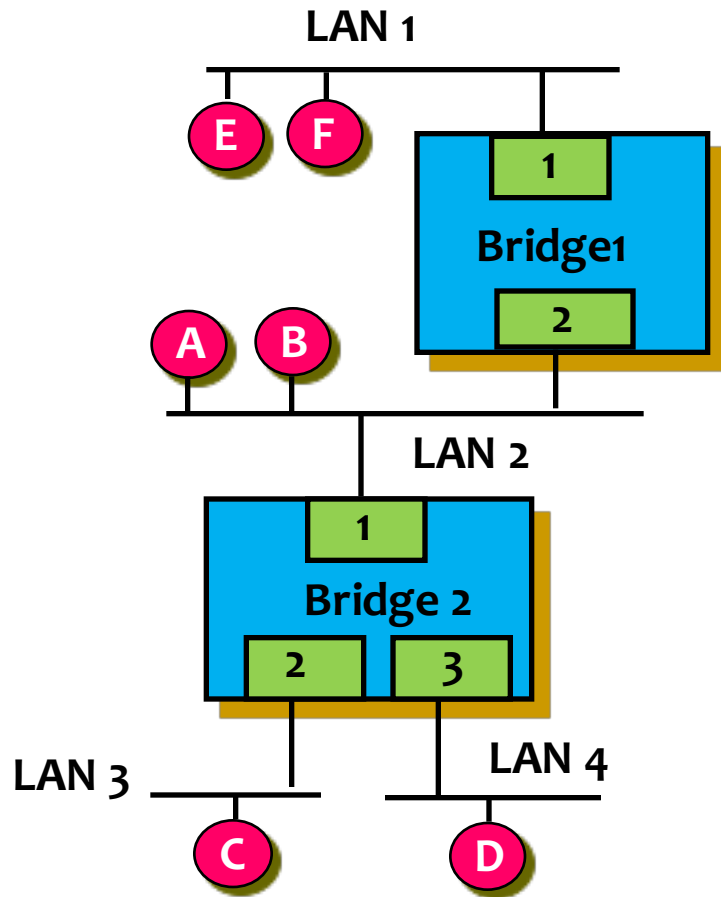

Filtering Database (Bridge 1)

MAC Addr	Port	Time (S)
A	2	20
B	2	18
C	2	25
D	2	4
E	1	5
F	1	12

Filtering Database (Bridge 2)

MAC Addr	Port	Time(S)
A	1	19
B	1	17
C	2	24
D	3	3
E	1	6
F	1	13

Outline

- Introduction
- **Frames Forwarding and Addresses Learning**
- Loop Problem and Resolution
- Spanning Tree Algorithm
- Spanning Tree Maintenance

Forwarding and Address Learning Algorithm

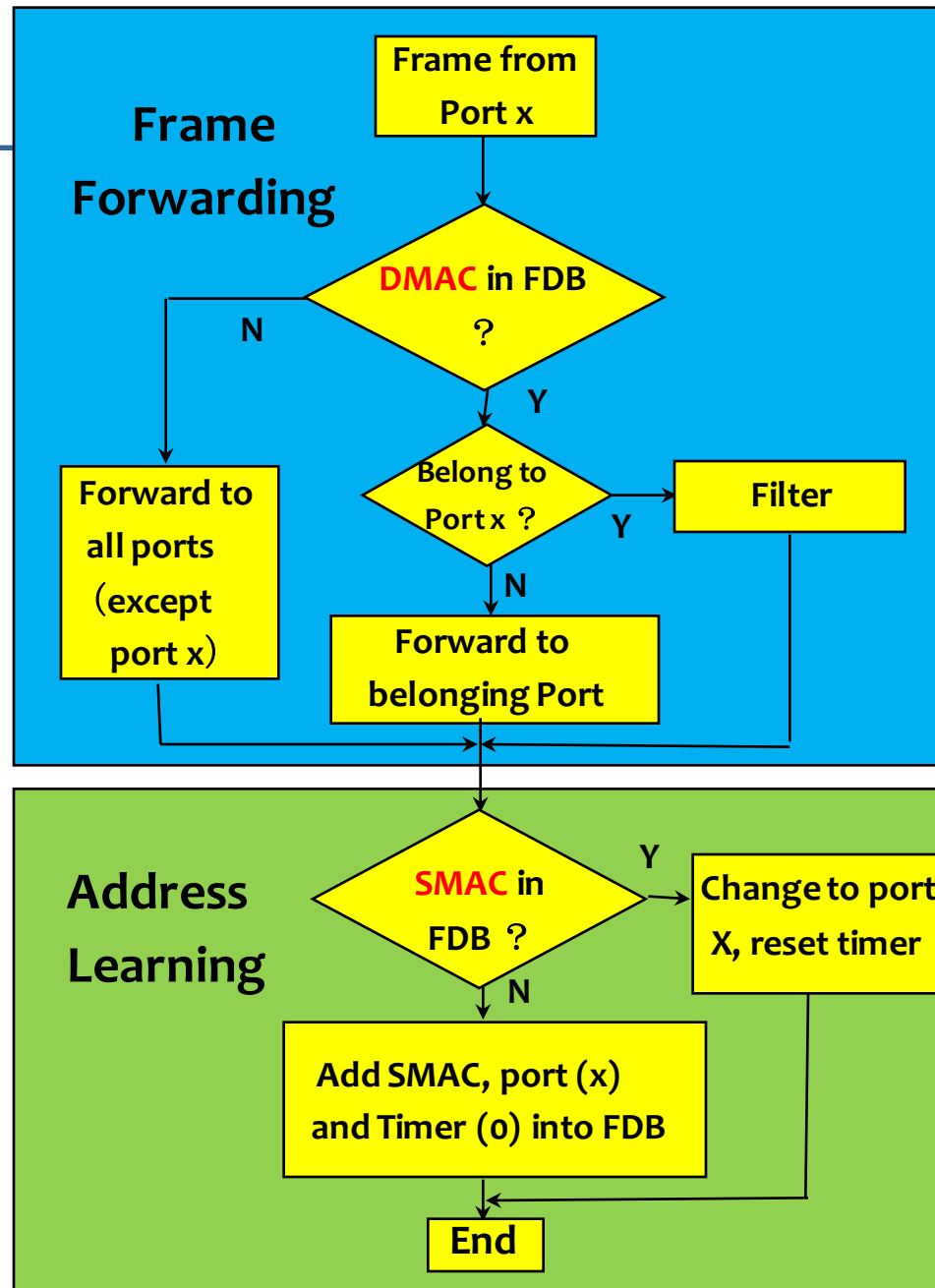

Addresses Learning Example

1. A -> E
2. B -> D
3. C -> B
4. D -> A
5. E -> C

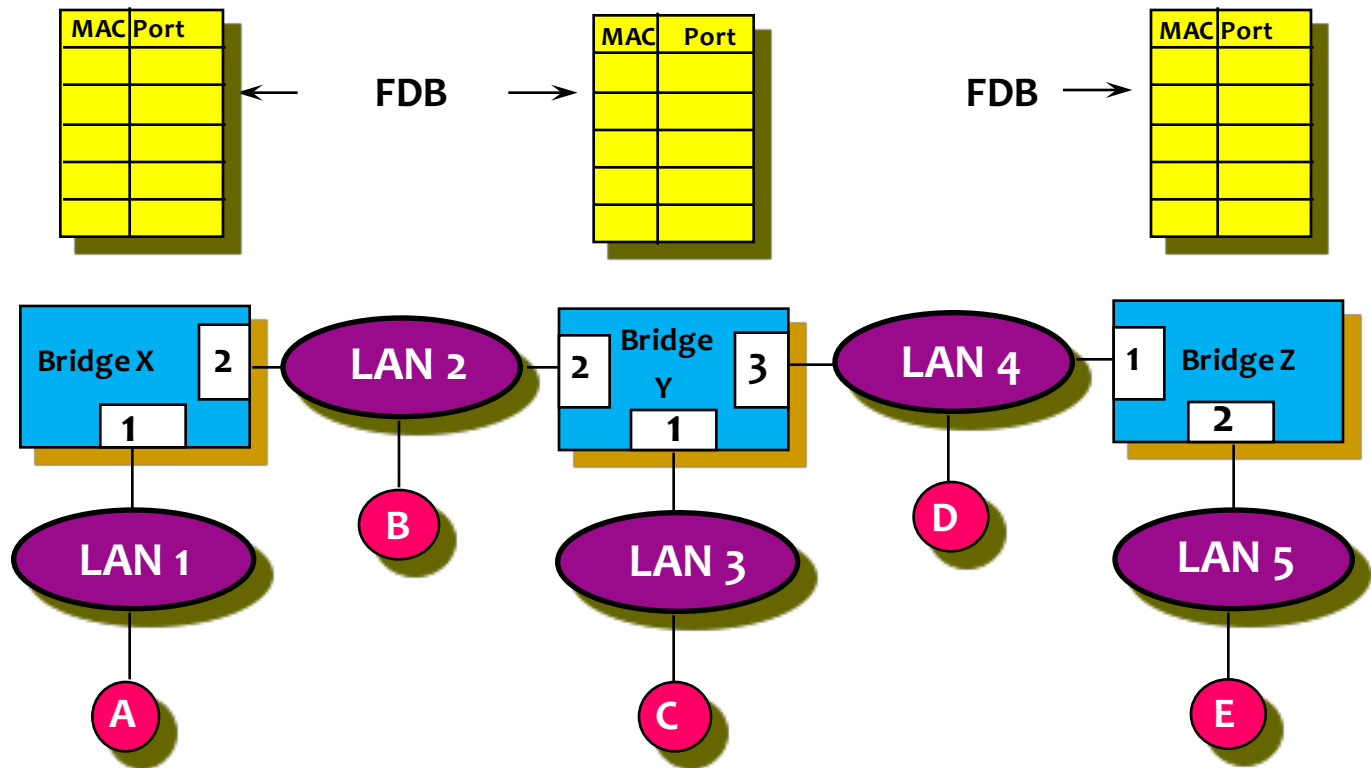

Addresses Learning Example (A→E)

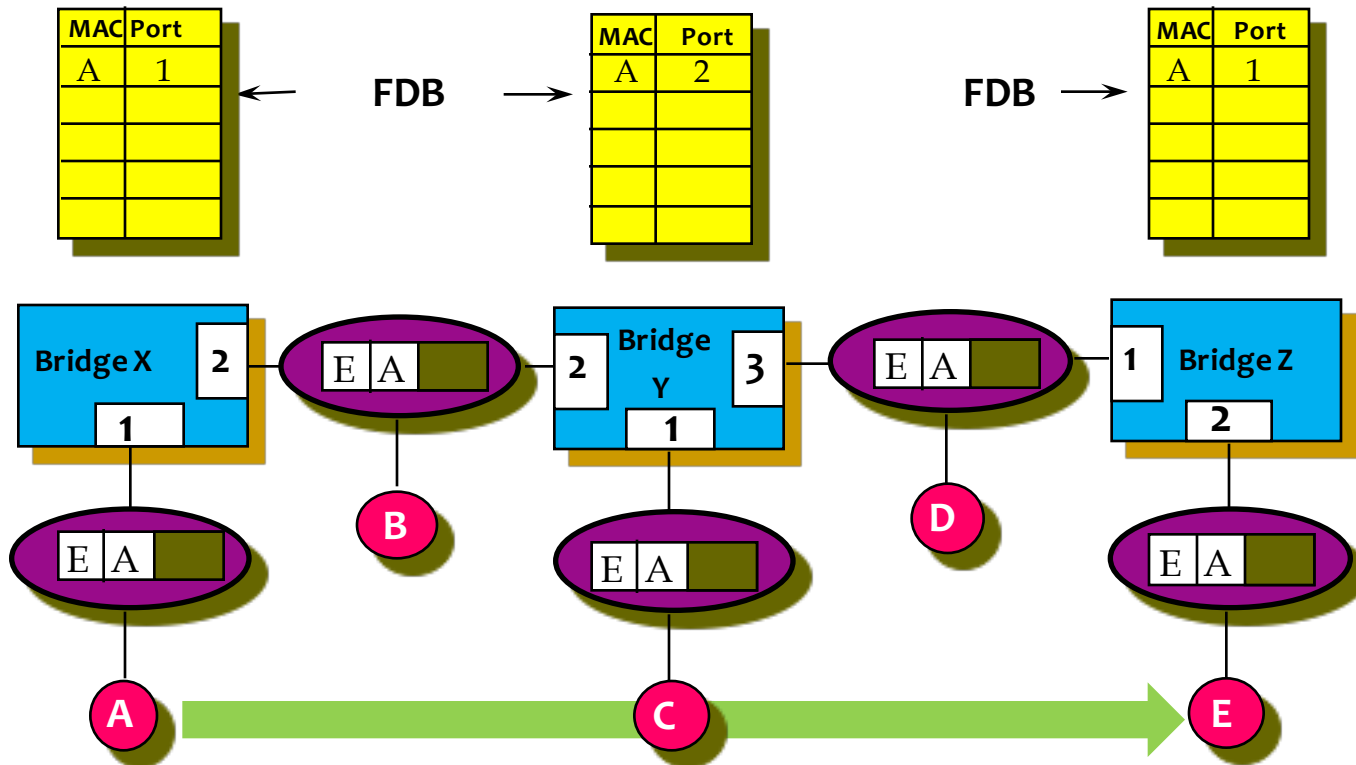

Addresses Learning Example (B → D)

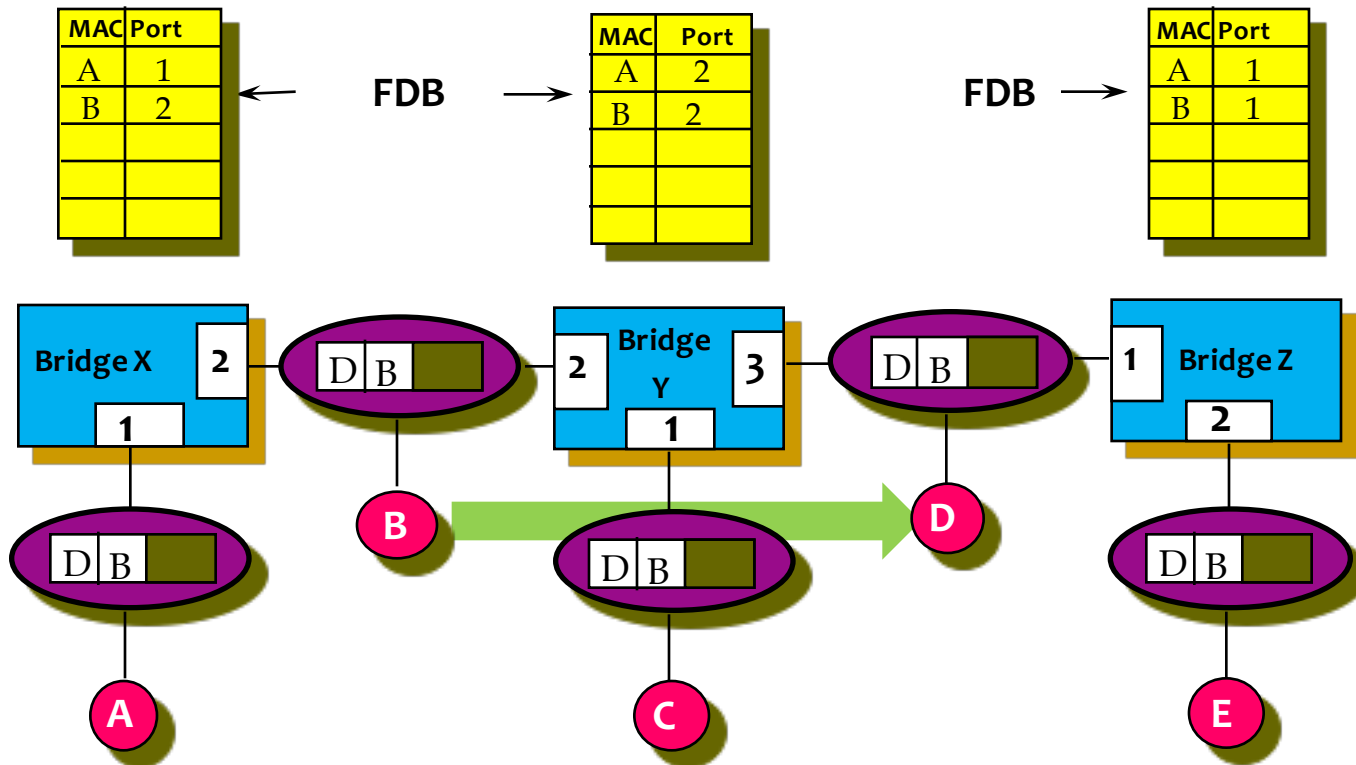

Addresses Learning Example (C→B)

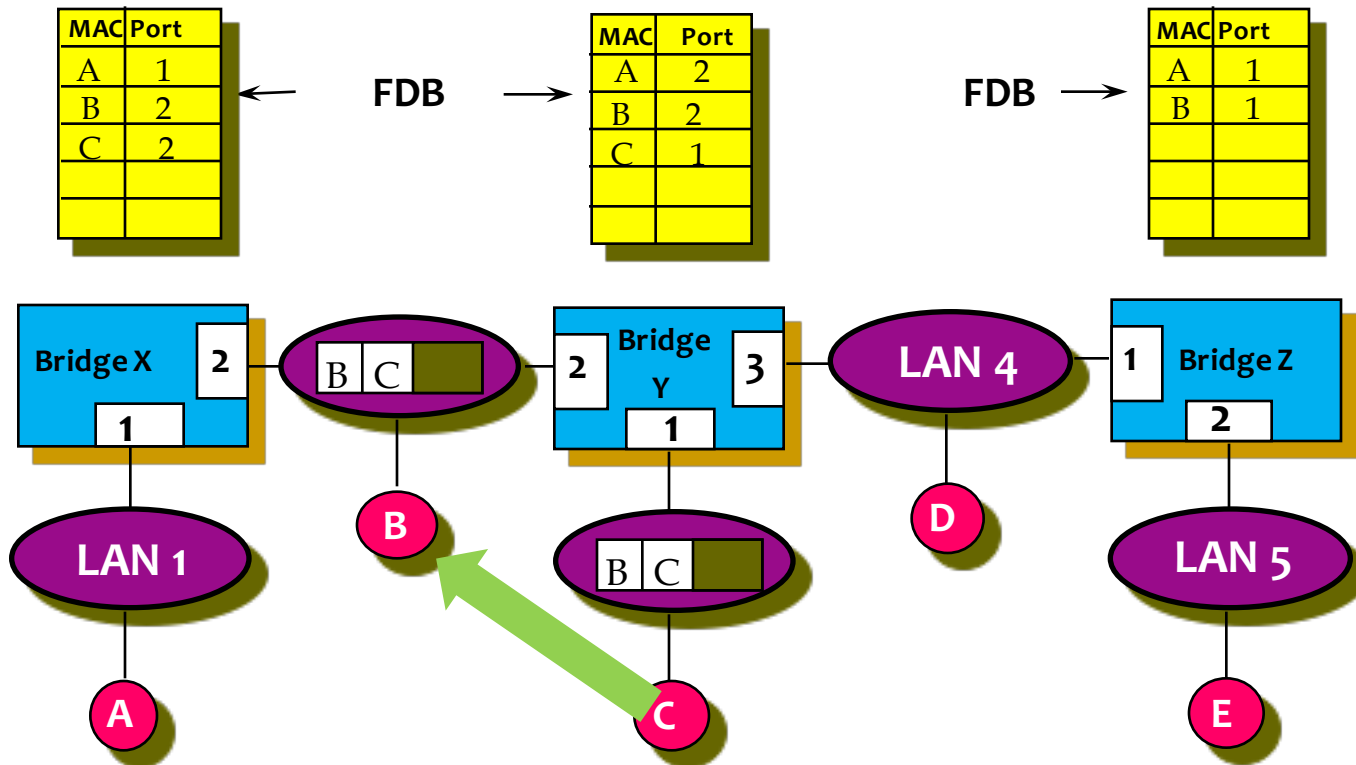

Addresses Learning Example (D→A)

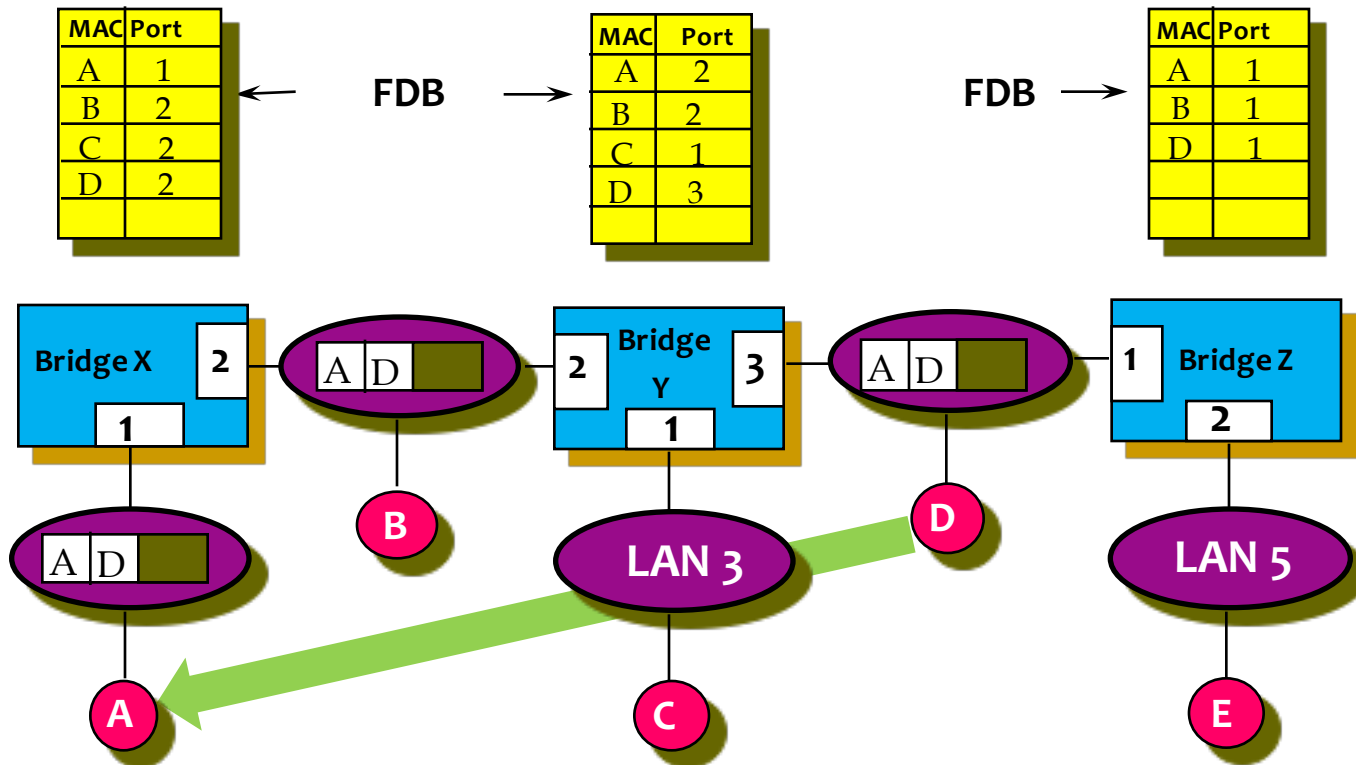

Addresses Learning Example (E→C)

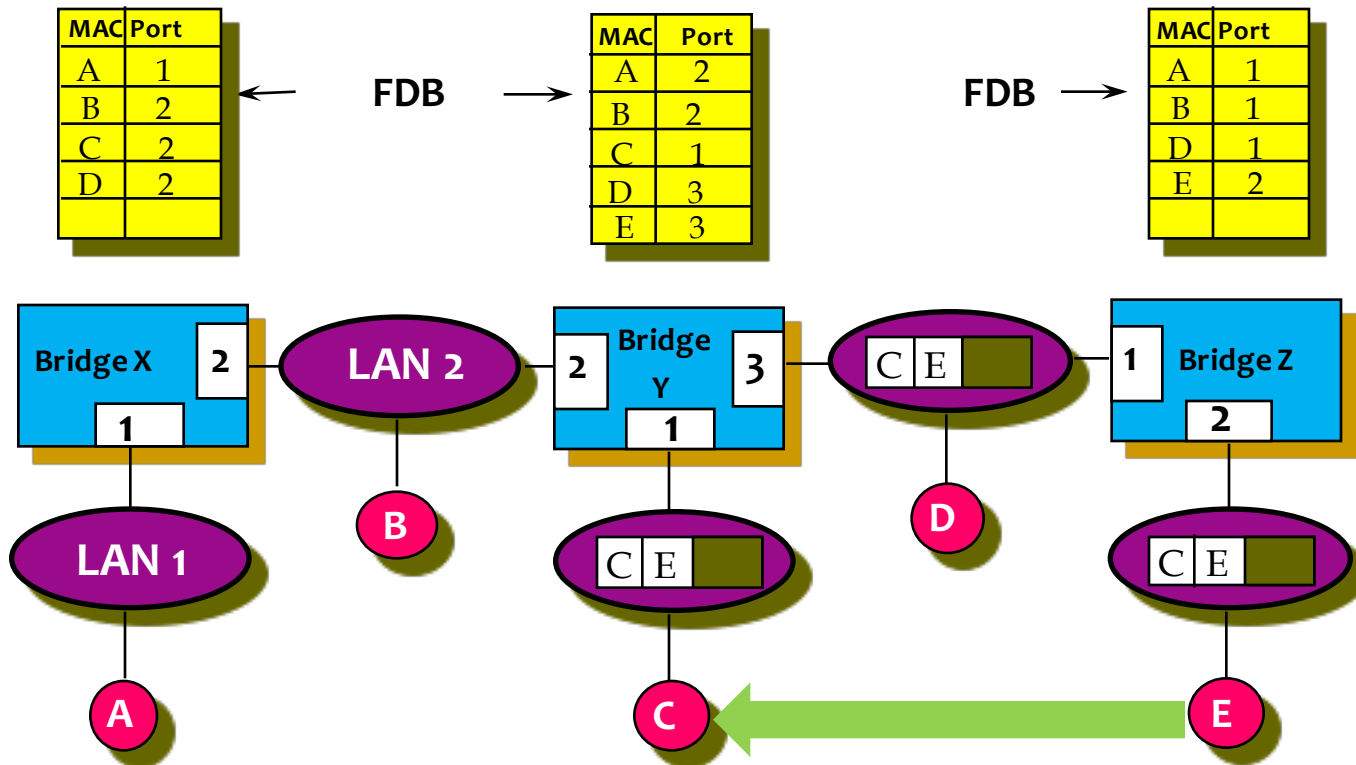

Outline

- Introduction
- Frames Forwarding and Addresses Learning
- **Loop Problem and Resolution**
- Spanning Tree Algorithm
- Spanning Tree Maintenance

Loop Problems and Resolution

- Loops provide network reliability
- But loops make frames duplication
- Loops also make wrong address learning

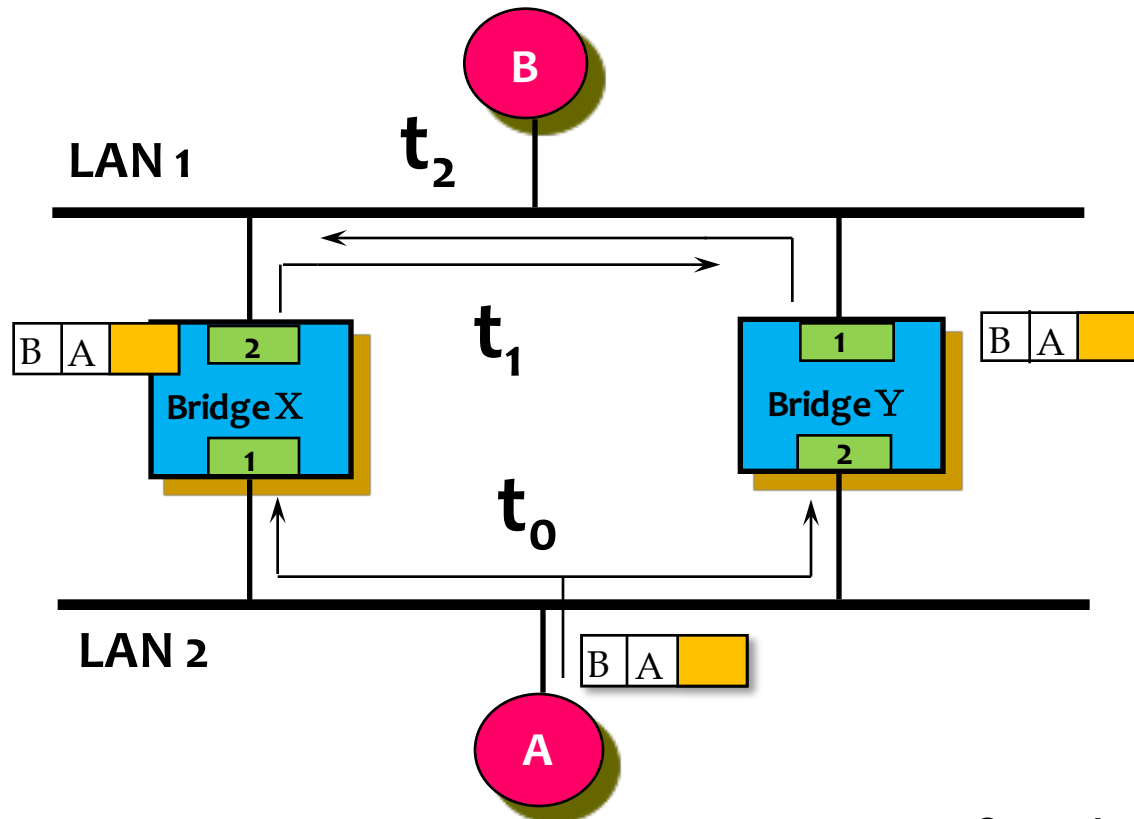

Graph Representation of a BLAN

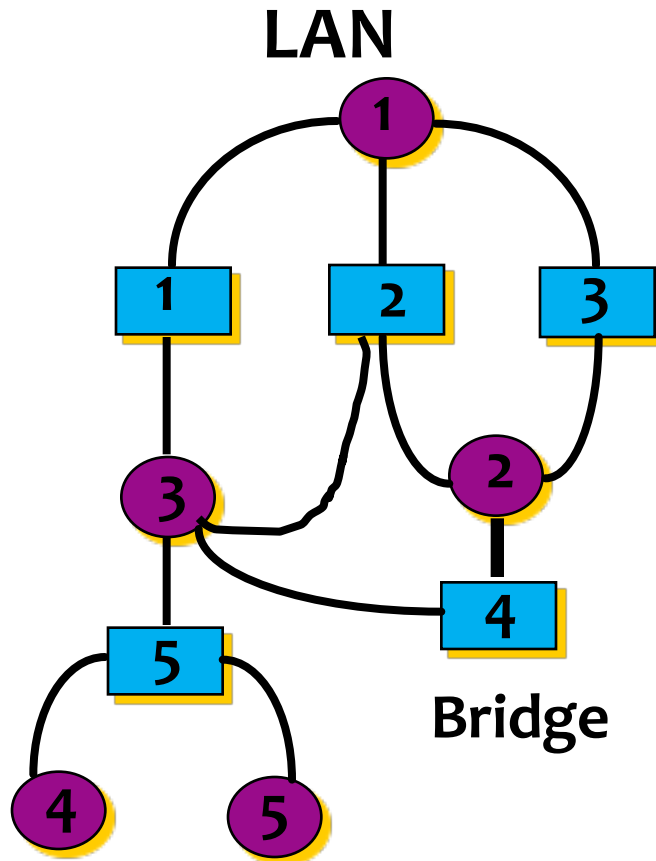

Spanning Tree

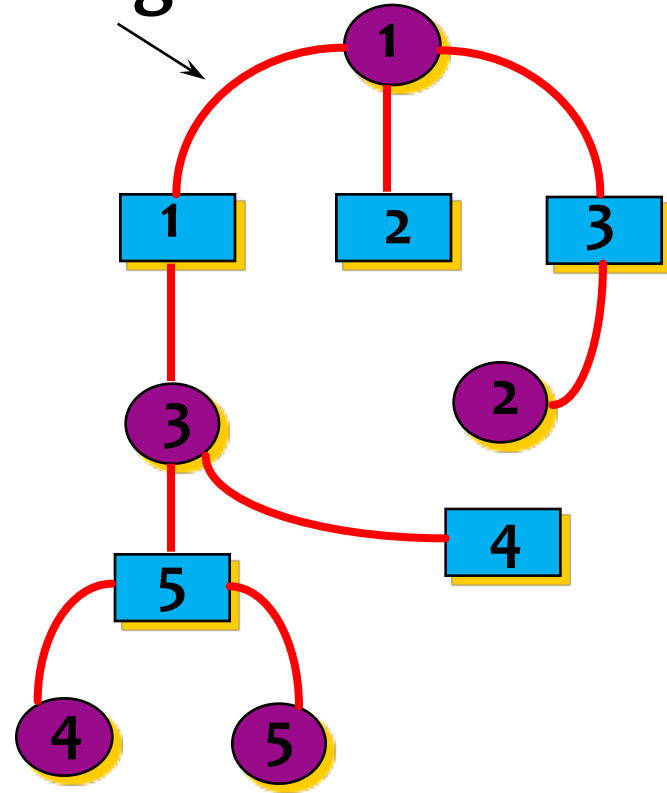

Spanning Tree Example 1

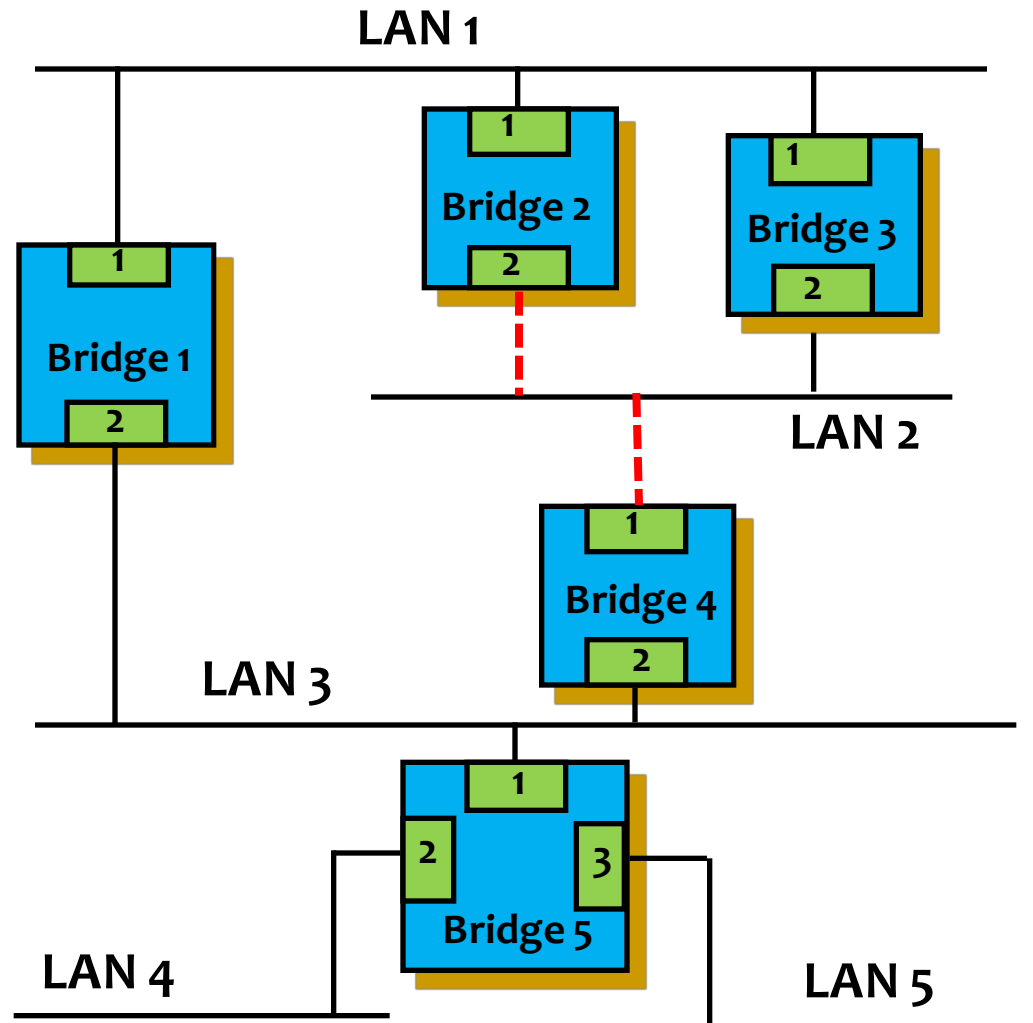

Spanning Tree Example 1 (Continued)

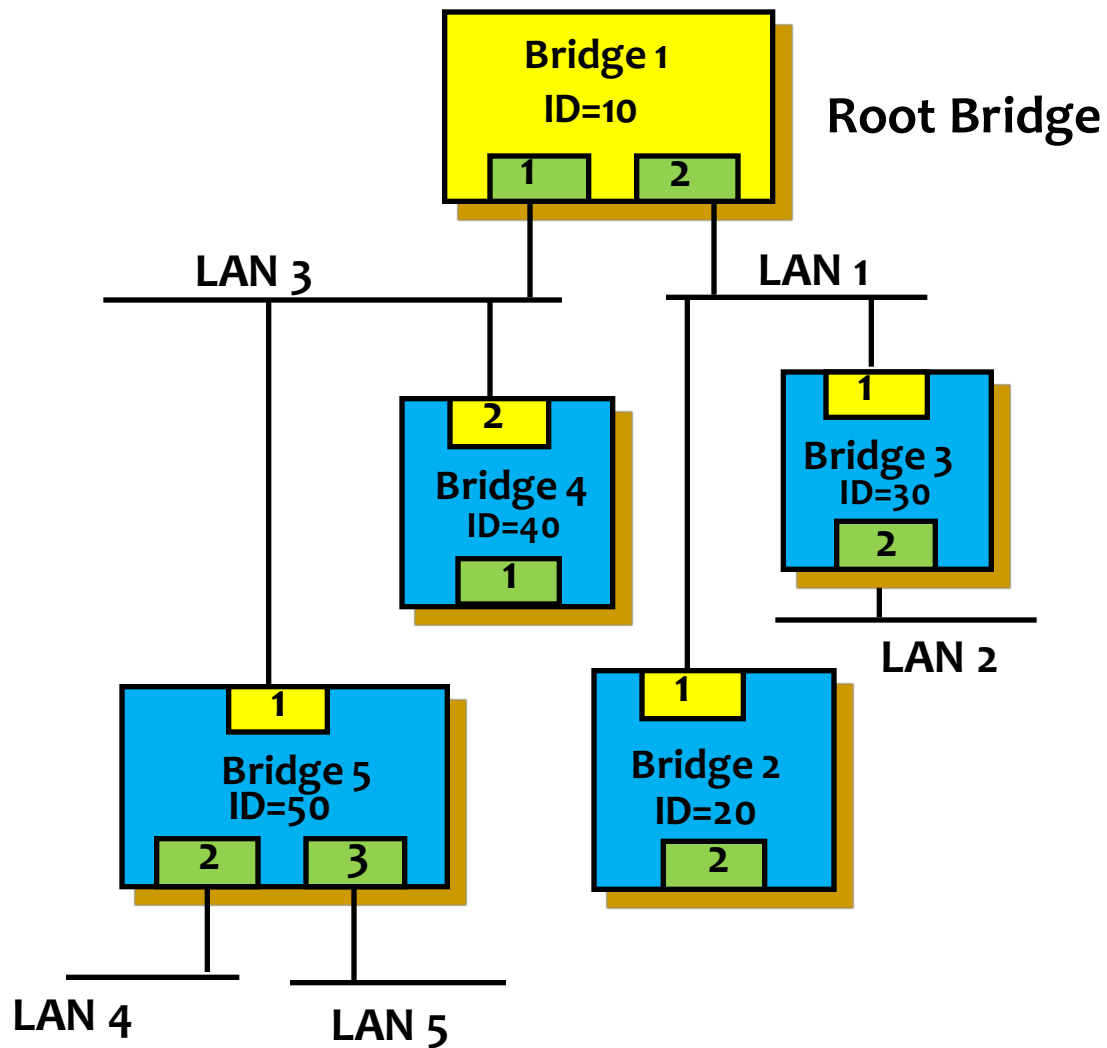

Outline

- Introduction
- Frames Forwarding and Addresses Learning
- Loop Problem and Resolution
- **Spanning Tree Algorithm**
- Spanning Tree Maintenance

Spanning Tree Algorithm (requirements)

■ Bridges

- Each bridge is assigned a unique identifier (8 octets):
 - ▶ Priority part (two octets): programmable
 - ▶ address part (six octets): MAC address
- A special group MAC address for all bridges :
01-80-C2-00-00-00 (Multicast address)
10000000-00000001-01000011-
- Each port of a bridge has a unique port identifier.

Spanning Tree Algorithm (definitions)

- **Root Bridge:** The bridge with the lowest value of bridge identifier.
- **Path Cost:** For each port, the cost of transmitting a frame onto a LAN.
- **Root Port:** For each bridge, the port on the minimum-cost path to the root bridge.
- **Root Path Cost:** For each bridge, the cost of the path to the root bridge with minimum cost.
- **Designated Bridge:** For each LAN, the bridge that provides the minimum cost path to the root bridge. The only bridge allowed to forward frames to and from the LAN.
- **Designated Port:** The port of the designated bridge that attaches the bridge to the LAN. All internet traffic to and from the LAN pass through the designated port.

Spanning Tree Example 2

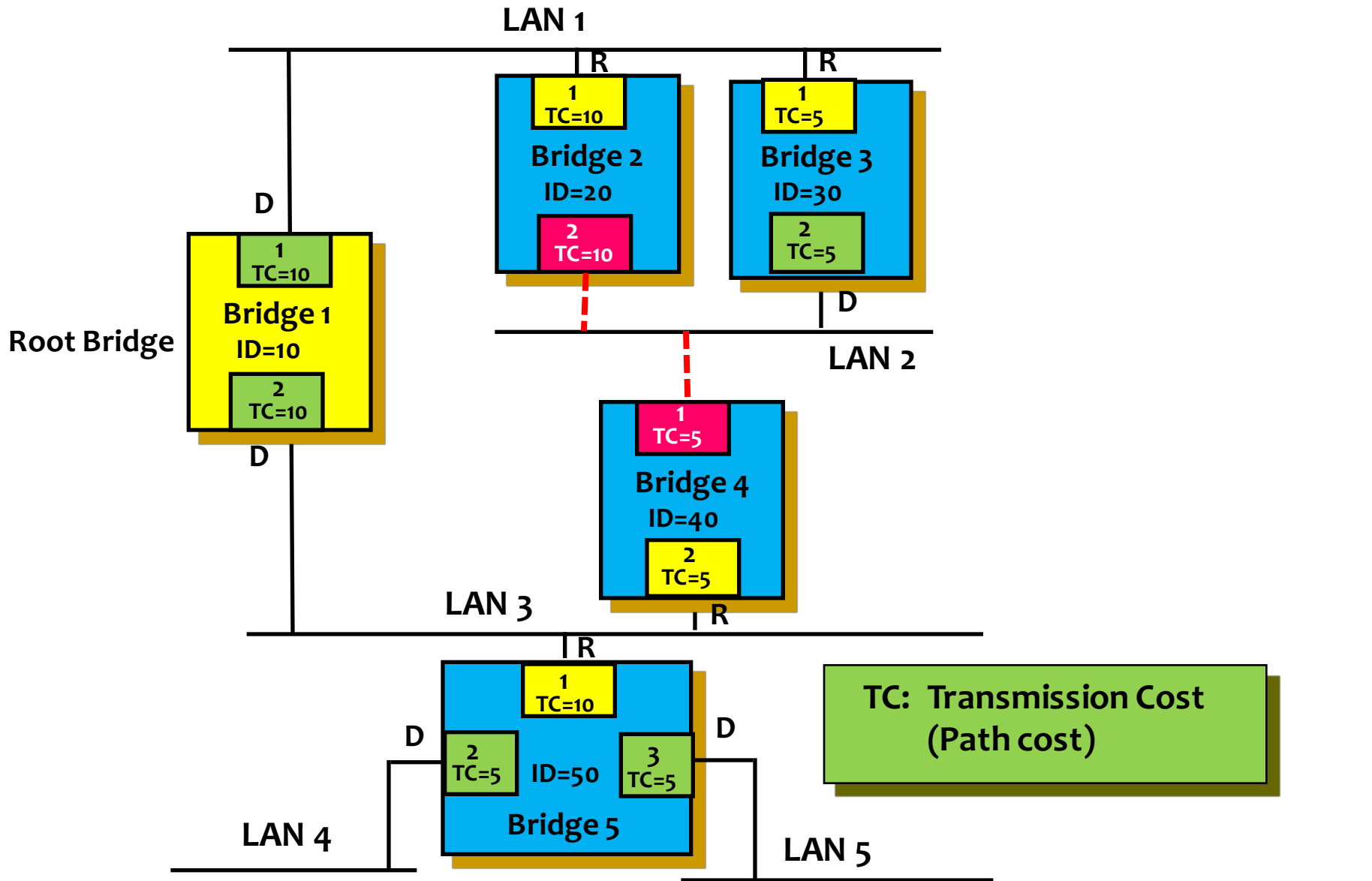

Spanning Tree Example 2 (continued)

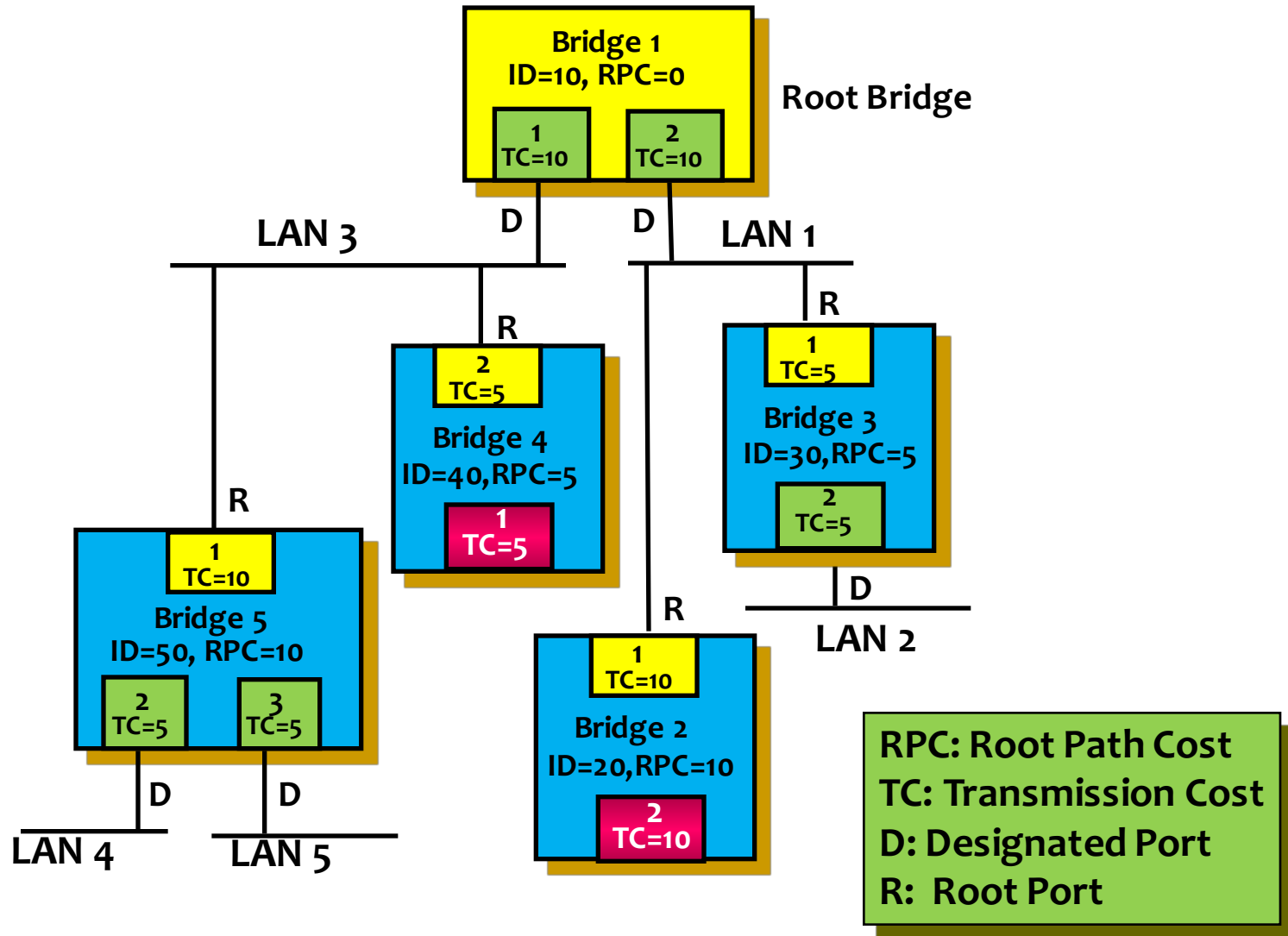

Spanning Tree Algorithm

■ Three Steps:

- 1. Determine the root bridge.**
- 2. Determine the root port on all other bridges.**
- 3. Determine the designated port on each LAN.**
 - The port with the minimum root path cost.
 - In the case of two or more bridges with the same root path cost, the highest-priority bridge is selected.
 - If the designated bridge has two or more ports attached to this LAN, then the port with the lowest value of identifier is selected.

Bridge Port State Diagram

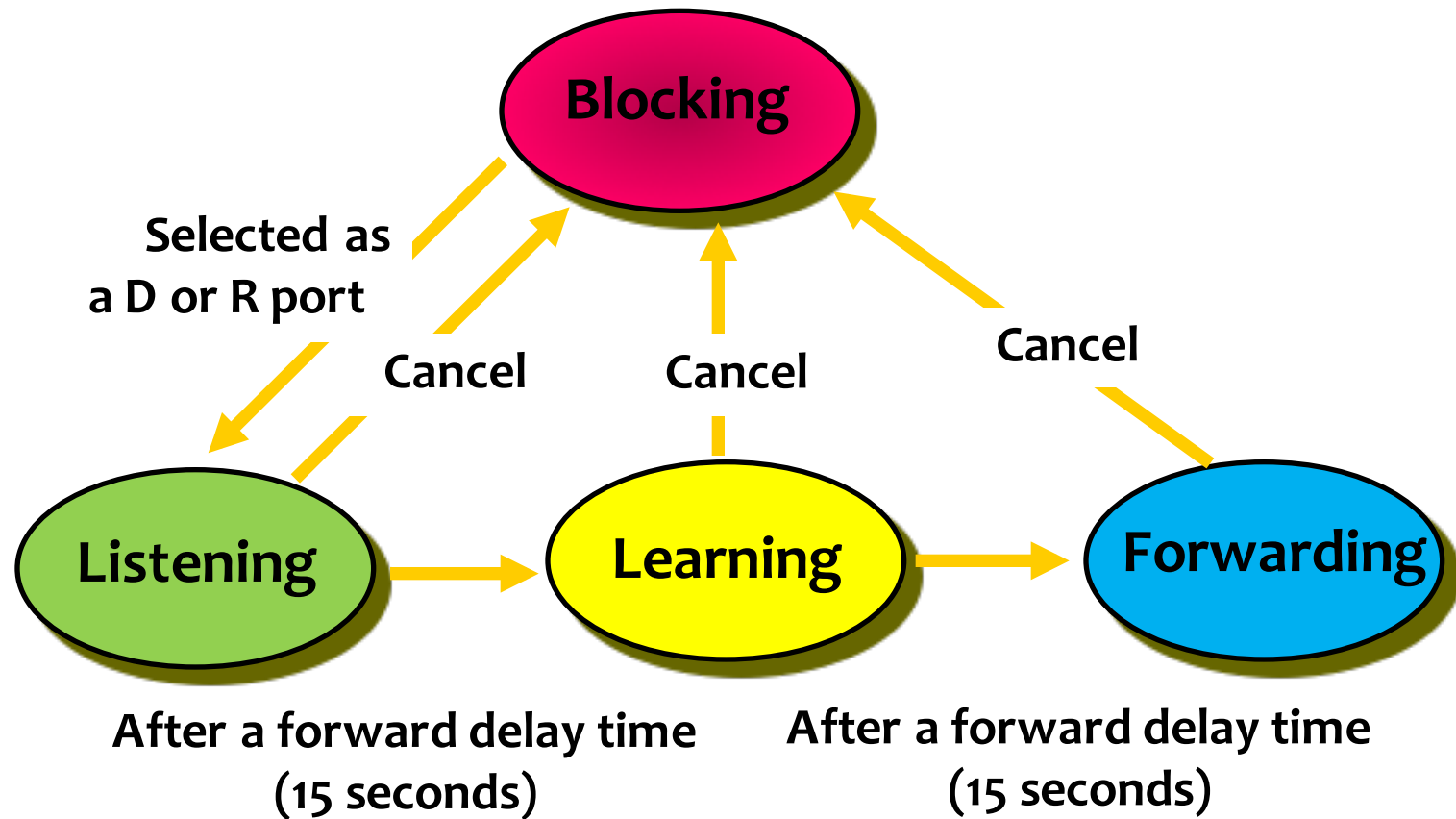

Bridge Protocol Data Unit (BPDU)

Bytes

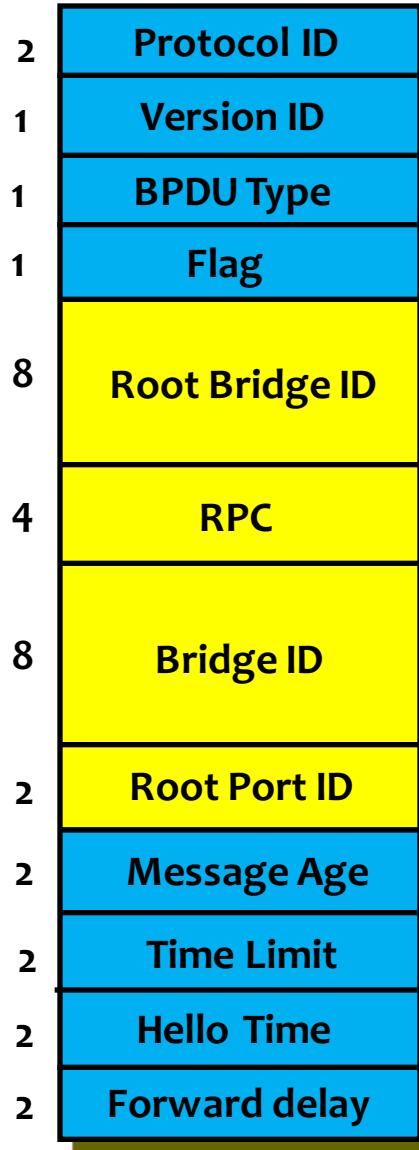

(a) Network Configuration BPDU

Bytes

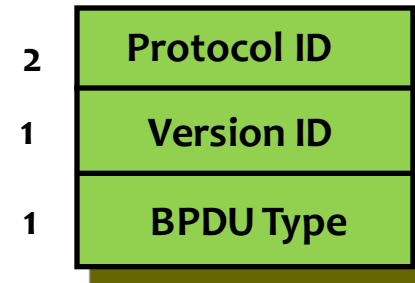

(b) Topology Change BPDU

Spanning Tree Algorithm Example

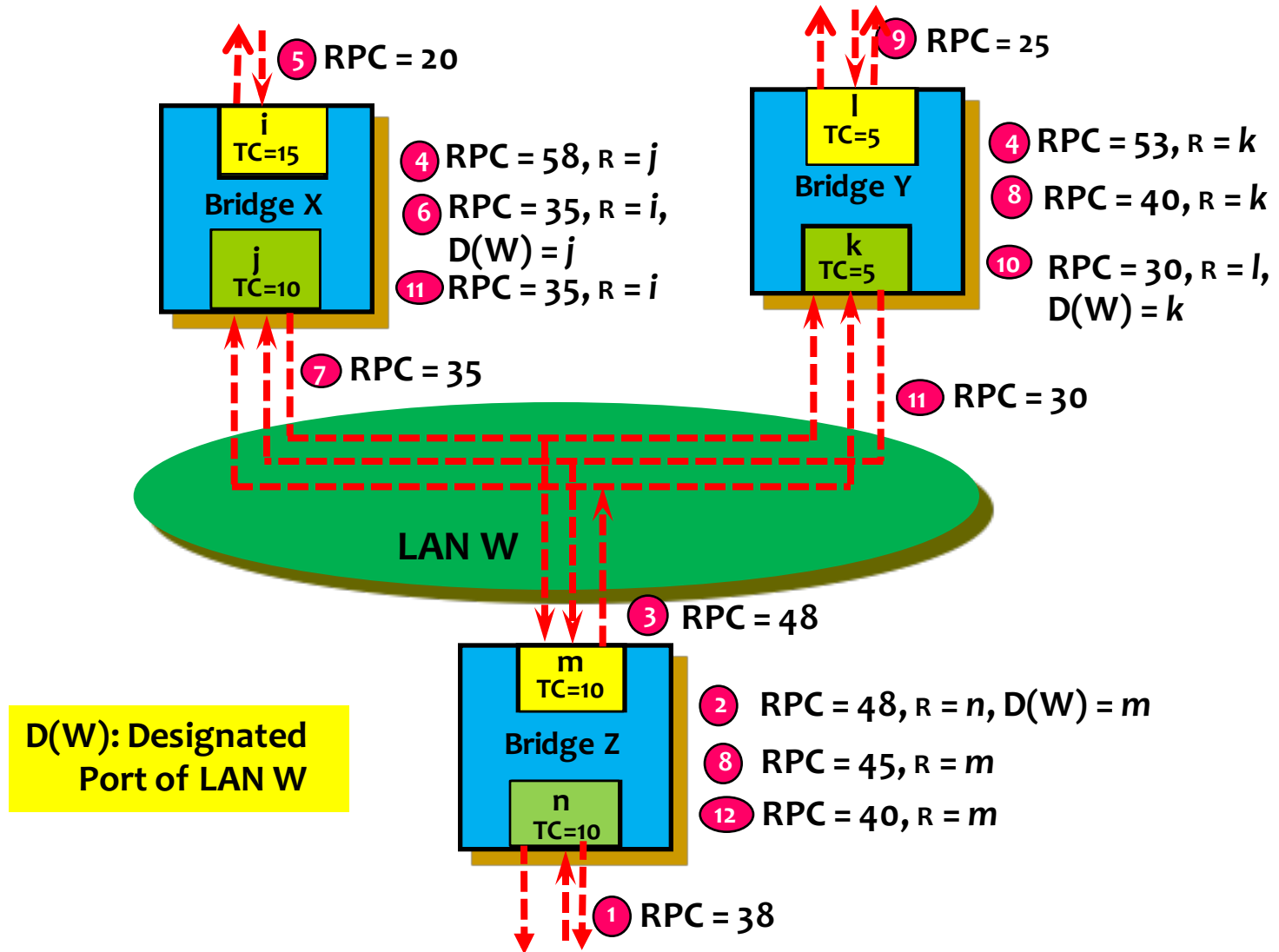

Spanning Tree Algorithm Example (Continued)

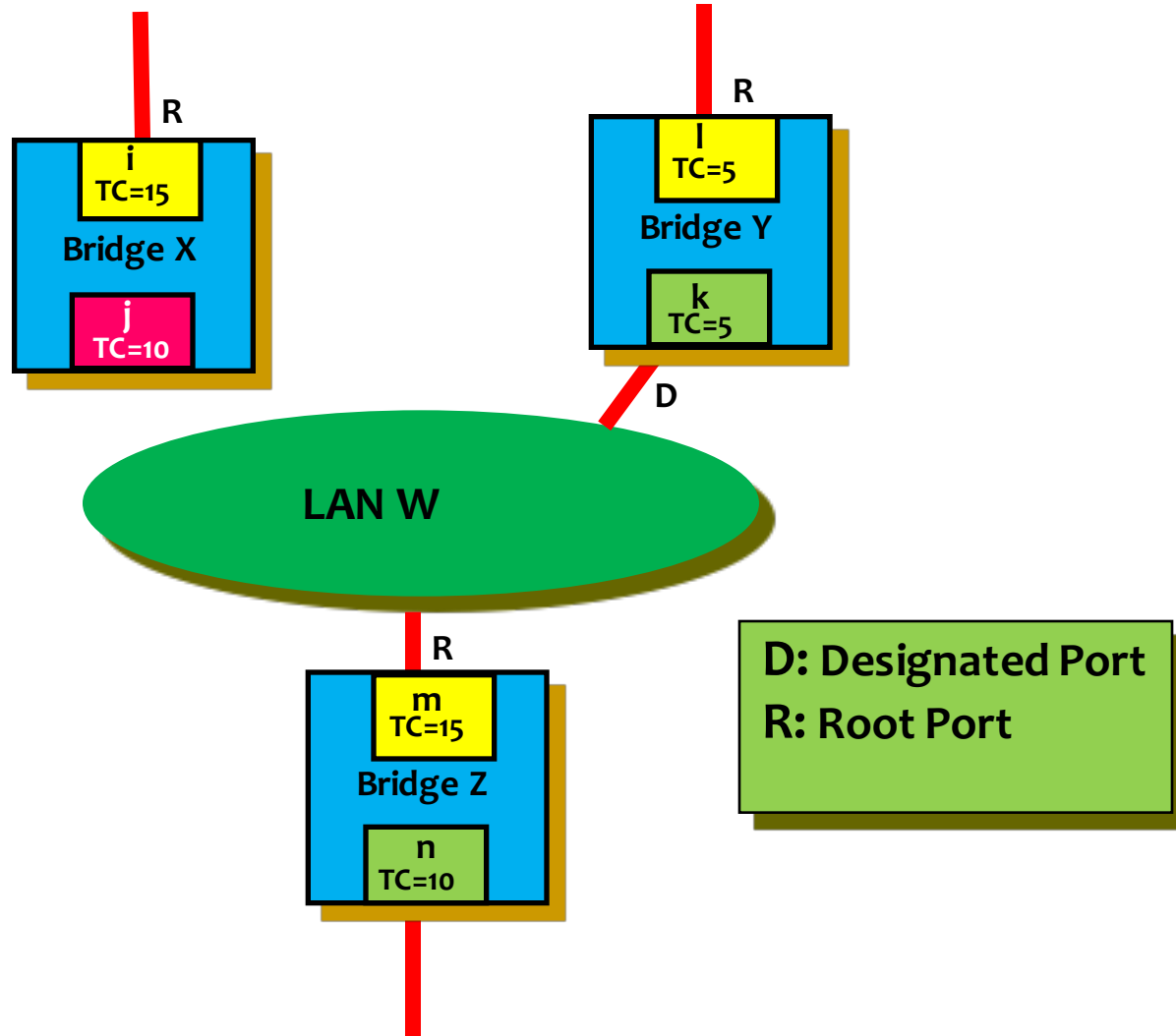

Spanning Tree Features

- The spanning tree constructed by the IEEE 802.1D algorithm has the features that **for each bridge, the shortest path (minimum root path cost, RPC) to the root bridge is included.**
- For each LAN, **the shortest path (minimum root path cost, RPC) to the root bridge via the designated bridge is included.**
- So the spanning tree usually is not a minimum cost spanning tree.
- The spanning tree of a BLAN (or switches connected network) is **predictable or deterministic.**
- Thus, given a BLAN topology (with any loops) and configuration parameters, the spanning tree of the BLAN can be calculated manually.

The Spanning Tree is Predictable

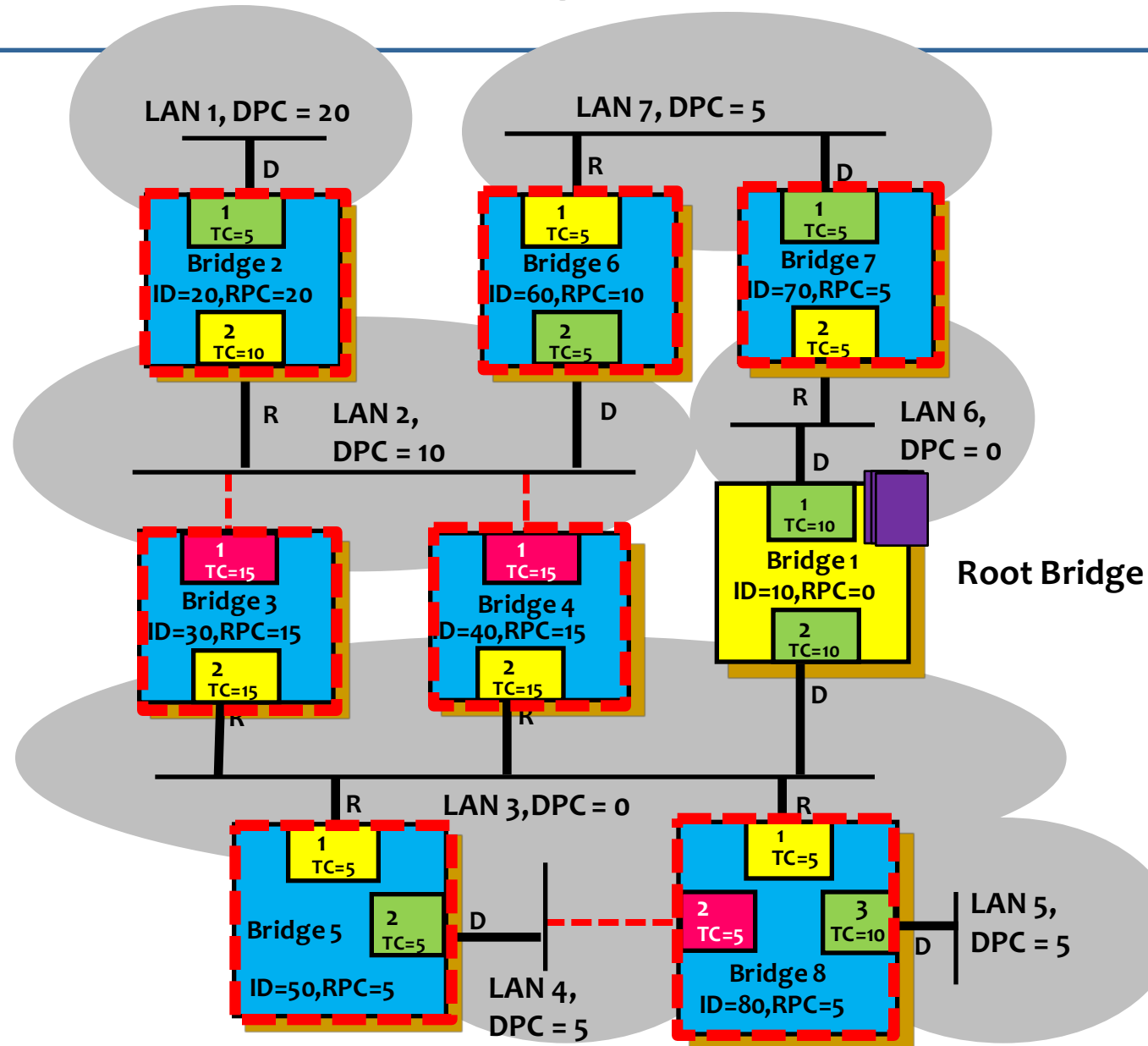

Outline

- Introduction
- Frames Forwarding and Addresses Learning
- Loop Problem and Resolution
- Spanning Tree Algorithm
- **Spanning Tree Maintenance**

Spanning Tree Maintenance

- The transmission of the configuration BPDU is triggered by root.
- The root will **periodically** (once every Hello time) issue a **configuration BPDU** on all LANs to which it is attached.
- A bridge that receives a configuration BPDU from its root port passes that information to all LANs for which it believes itself to be the designated bridge.
- A cascade of configuration BPDUs throughout the spanning tree.
- A bridge may change the spanning tree topology
- A **TCN BPDU is reliable relayed** up the new spanning tree to the root bridge (bridge by bridge).
- The root will set the **Topology Change flag** in all configuration messages transmitted for some time.

Spanning Tree Maintenance

Example 1 (Bridge Faults)

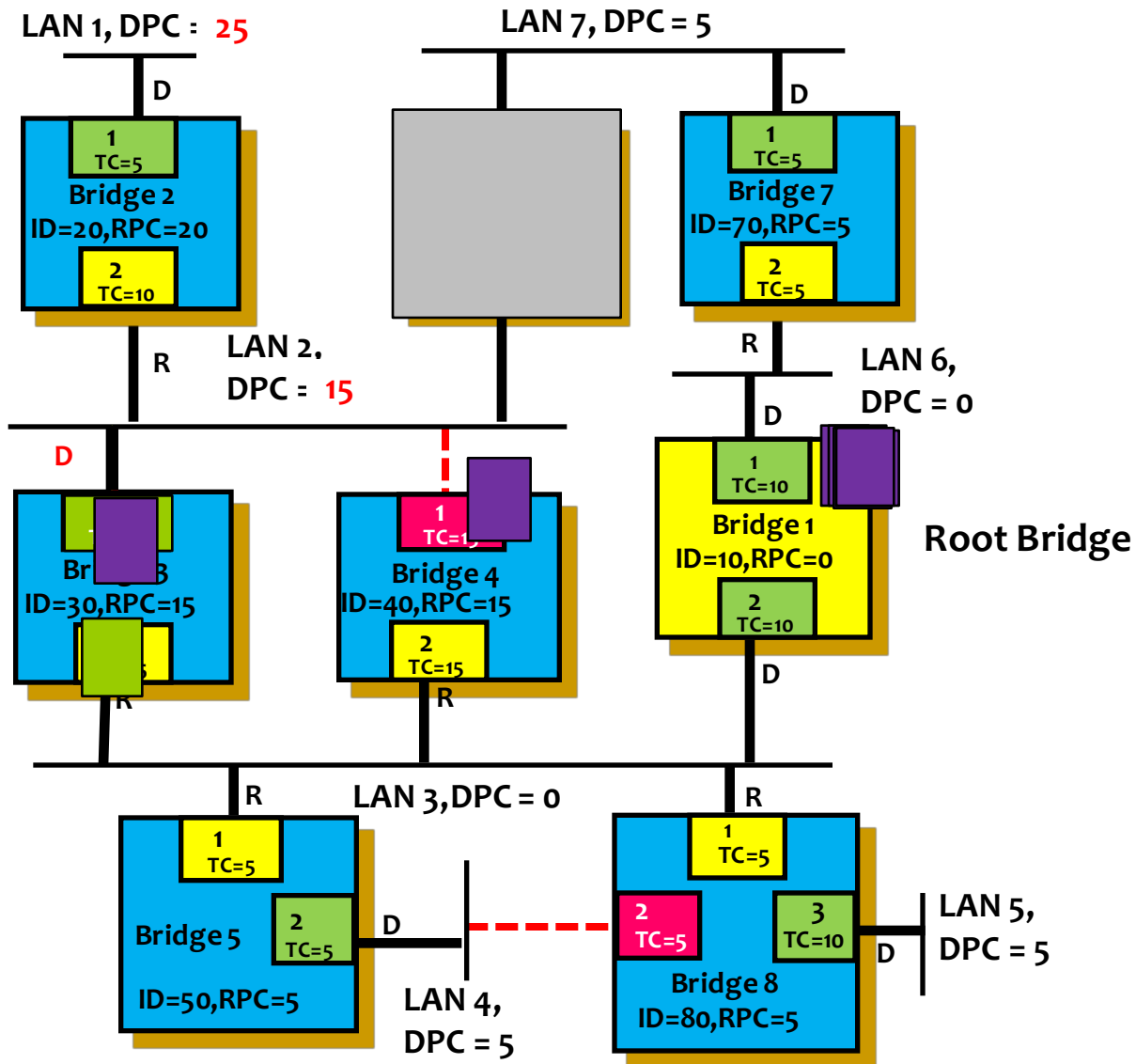

Spanning Tree Maintenance

Example 1 (Bridge Faults)

- Assume Bridge 6 (ID = 60) faults.
- Then all the Hello BPDUs sent from root bridge to Bridge 6 will not be forwarded to LAN 2 any more.
- The Bridges 3 and 4 in LAN 2 will trigger the timeout event individually which means the Designated bridge 6 for LAN 2 was gone.
- Then they will try to serve as the Designated bridge of LAN 2 by forwarding a configuration BPDU.
- Assume bridge 4 sends the BPDU first with a RPC = 15.

Spanning Tree Maintenance

Example 1 (Bridge Faults)

- Then bridge 3 will return another BPDU with RPC=15 since it's priority is higher than bridge 4 (same RPC, smaller ID).
- After two forwarding delays, bridge 3 will become the new Designated bridge of LAN2 and the DPC becomes 15.
- Also the DPC of LAN 1 is changed from 15 to 25.
- Bridge 3 then sends a Topology Change Notification (TCN) BPDU to root bridge.
- The root will set the Topology Change flag in all configuration messages transmitted for some time.

Final Configuration of Example 1

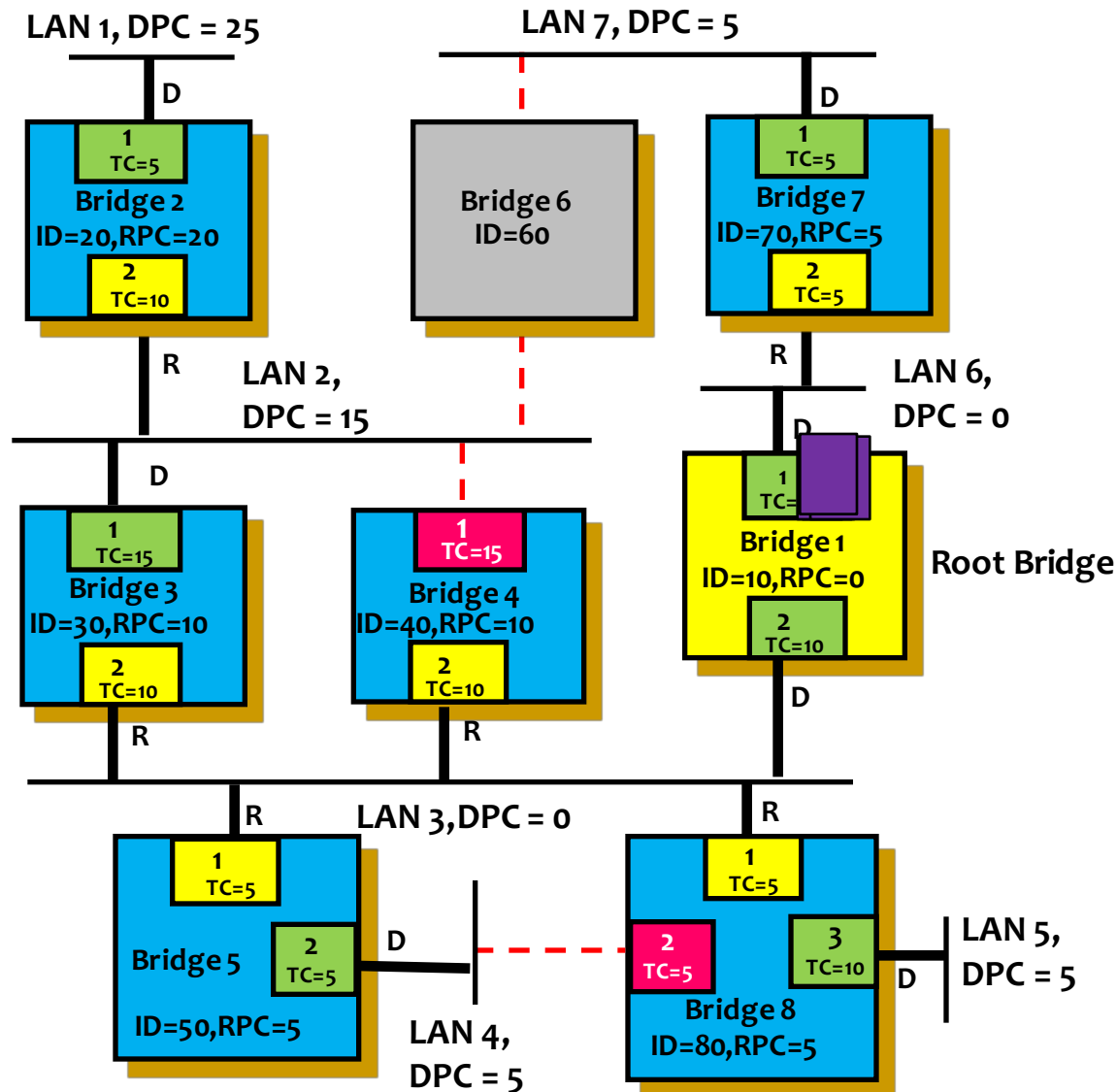

Spanning Tree Maintenance

Example 2 (LAN Faults)

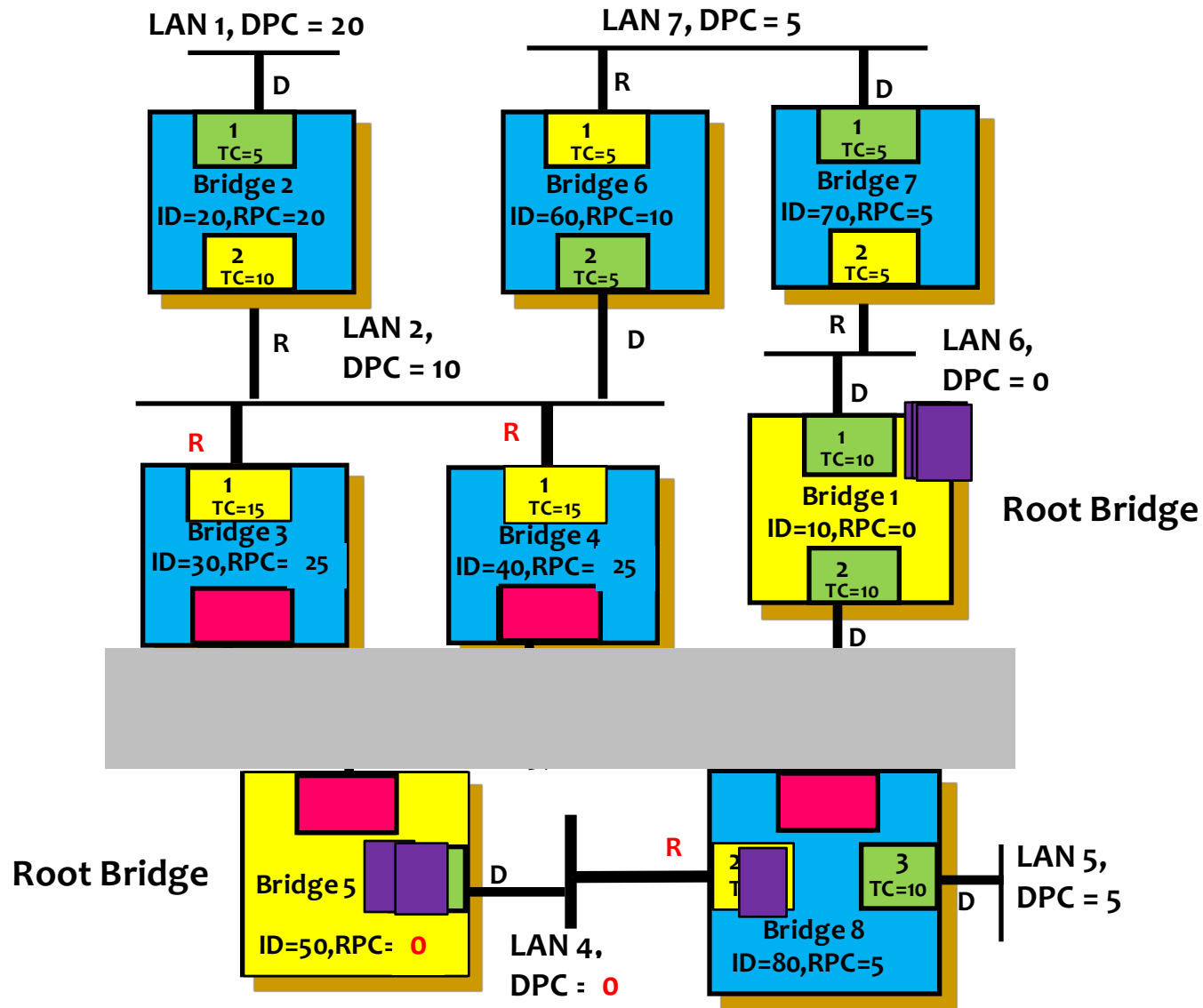

Spanning Tree Maintenance

Example 2 (LAN Faults)

- Assume LAN 3 faults.
- Then all the Hello BPDUs sent from root bridge to LAN 3 will be lost.
- All the ports connected to LAN 3, including port 2 of bridge 3, port 2 of bridge 4, port 1 of bridge 5, and port 1 of bridge 8, will become **“blocked” state** from **“forwarding” state**.
- All these bridges are now don't have **“R” port** (root port) and then try to be a root bridge.
- Bridges 3 and 4 still can receive the Hello BPDU from port 1, so they will change their root port to port 1.

Spanning Tree Maintenance

Example 2 (LAN Faults)

- Bridges 5 and 8 will exchange BPDU to compete as a new root follow the STP protocol.
- Assume bridge 8 sends the BPDU first with a RPC = 0.
- Then bridge 5 will return another BPDU with RPC=0 since it's priority is higher than bridge 8 (smaller ID).
- After two forwarding delays, bridge 5 will become the new root bridge and the port 1 of bridge 8 will become a root port.
- Finally, we have two separated (disconnected) spanning trees.

Final Configuration of Example 2

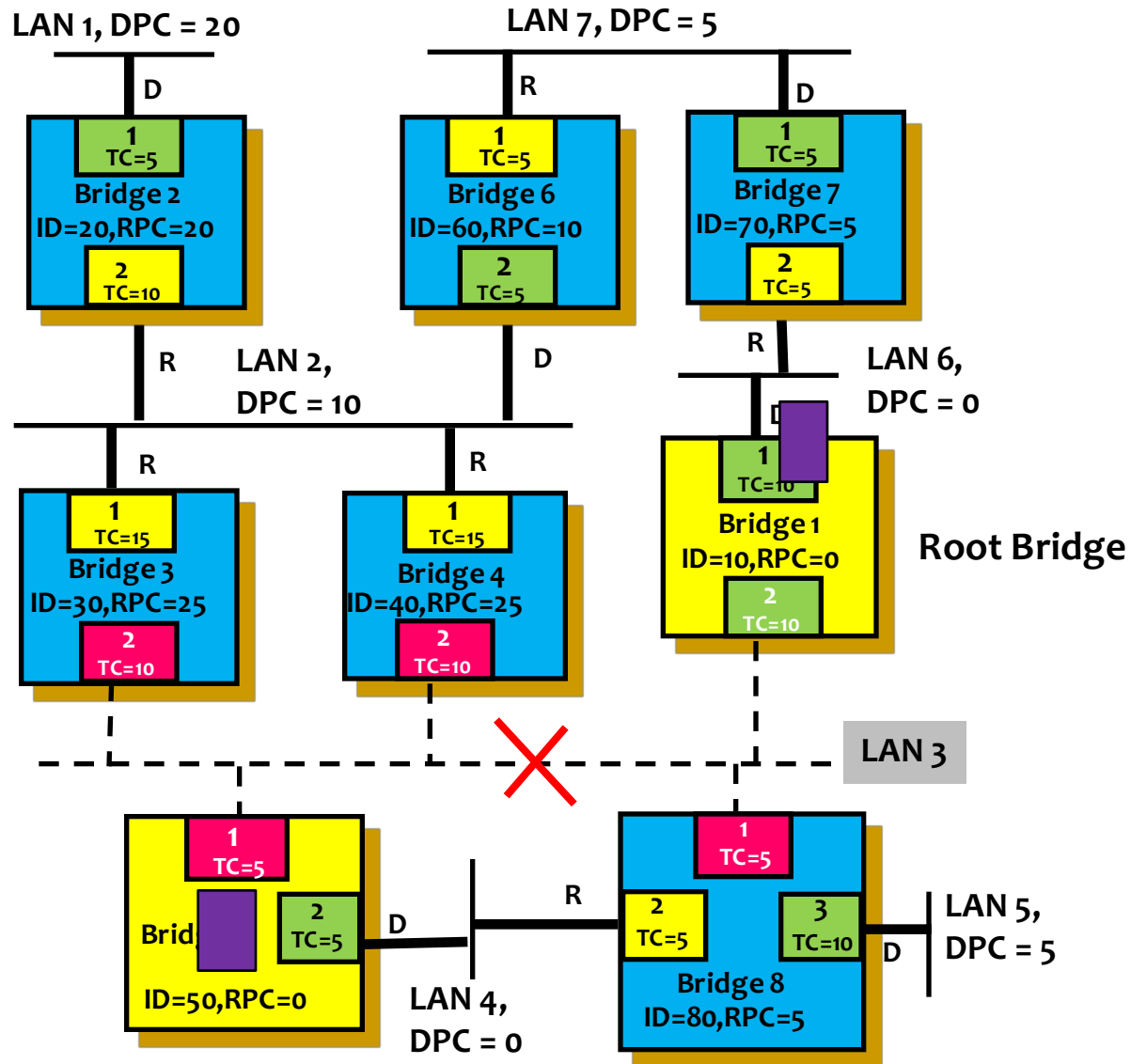

In Summary

- A bridge is a **layer 2 device** which relays frames among physically separated LANs and makes the physical LANs appear as **one logical LAN** to the end stations
- Basic functions of a bridge:
 - Frame **Forwarding** and **Filtering**
 - Address **Learning**
 - Resolving Possible **Loops** in the Topology
- The spanning tree constructed by the IEEE 802.1D algorithm has the features that **for each bridge, the shortest path (minimum root path cost, RPC) to the root bridge is included.**

In Summary

- For each LAN, **the shortest path (minimum root path cost, RPC) to the root bridge via the designated bridge is included.**
- The spanning tree of a BLAN (or switches connected network) is **predictable or deterministic.**
- Thus, given a BLAN topology (with any loops), the spanning tree of the BLAN can be calculated manually.
- The spanning tree algorithm has the ability to maintain the spanning tree by handling the **bridge faults** as well as **LAN faults.**

The Spanning Tree is Predictable

